



# SERVICE BULLETIN

SB-AG-85

Rev C: 10/03/2024

## 510 Gallon Series Tail Spring Forward Mount Support Struts Installation

Affected Aircraft Models	Serial Number Range
S2R-T34, S2R-H80, S2R-G10, R1340 S2R-510	ALL 101-145 & 501-528

*DAVID E. YARBROUGH*

David Yarbrough  
Director of Engineering

## TABLE OF CONTENTS

1. PURPOSE/REASON FOR PUBLICATION.....	4
2. SCOPE/COMPLIANCE.....	4
3. BY WHOM WORK WILL BE ACCOMPLISHED.....	4
4. APPROVAL .....	4
5. MAN HOURS .....	4
6. SPECIAL TOOLS .....	4
7. PARTS LIST .....	5
8. JACK .....	6
9. REMOVAL .....	6
10. INSPECTION.....	7
11. INSTALLATION .....	8
12. FINAL INSPECTION.....	11
13. COMPLIANCE .....	12

## LOG OF REVISIONS

**NOTE:** Reformatting and correction of typographical errors is not considered revision.

REV	PAGE	DESCRIPTION OF REVISION	BY:
IR	All	New Document Initial Release.	T. Surratt 07/30/2024
A	5, 8, & 9	Updated strut P/Ns -001 & -002 to -003 & -004.	T. Surratt 08/16/2024
B	8	Revised step 11.3. Added note to step 11.4. Deleted step 11.5 and moved notes to step 11.3.	T. Surratt 09/09/24
C	Cover	Extended Effectivity for S/N 101 from 143 to 145.	T. Surratt 10/03/24

## **1. PURPOSE/REASON FOR PUBLICATION**

Thrush Aircraft has been notified by one or more owners/operators of slippage of the tail spring forward mount on our 510 gallon series aircraft.

## **2. SCOPE/COMPLIANCE**

This Service Bulletin is released to all S2R aircraft with the 510 gallon hopper owners/operators as instructions for inspection of the tail gear assembly and installation of the tail spring forward mount support struts.

## **3. BY WHOM WORK WILL BE ACCOMPLISHED**

The work is to be accomplished by an FAA Certified A&P Mechanic or foreign equivalent.

## **4. APPROVAL**

This Service Bulletin is approved by the FAA and the Director of Engineering at Thrush Aircraft, LLC.

## **5. MAN HOURS**

1 hour may be required.

## **6. SPECIAL TOOLS**

N/A

## 7. PARTS LIST

QTY	PART NUMBER	NOMENCLATURE	NOTE
1	322120030-003	LH Fwd Tail Mount Strut	Supercedes -001
1	322120030-004	RH Fwd Tail Mount Strut	Supercedes -002
2	322120031-001	Bushing	Fwd Mount
1	NAS6206-66D	Bolt	Fwd Mount
6	NAS1149F0632P	Washer	Fwd Mount
6	NAS1149F0663P	Washer (AN960-616)	Fwd Mount
1	AN310-6	Nut	Fwd Mount
1	MS24665-300	Cotter Pin	Fwd Mount
2	NAS6606-56	Bolt	Aft Mount
2	MS21042L6	Nut	Aft Mount

**\*\*\* Parts listed above are included in the SB-AG-85 kit. \*\*\***

## 8. JACK

When using the jack points to lift the aircraft, all hopper loads should be removed. A jack point is provided on the tail wheel trunnion attach fitting on the lower left longeron. (Reference Figure 8.1)

1. Chock the forward main landing gear wheels.
2. Place an appropriate jack at the aft jack point of the aircraft and carefully raise the aircraft enough to give plenty of ground clearance to remove the tail gear assembly.



**Figure 8.1 Jack Point Location**

## 9. REMOVAL

1. Remove the cotter pin and axle castellated nut and the spacer, then remove the tire/wheel assembly.
2. Disconnect the flex control lock cable at the pivot arm and cable hold down clamp.
3. Disconnect the centering springs from the tail wheel centering arm assembly by removing the attach bolt.
 

**NOTE:** Do not alter the lock cable nor the elevator travel stops. Alteration of the tail gear lock cable or the elevator travel stops will require re-rigging of the tail wheel locking system.
4. Remove the two bolts that hold the lower spring support block to the upper support block.
5. Remove the main leaf spring assembly by removing the bolt that is holding the spring to the trunnion assembly.
6. Remove the trunnion assembly from the fuselage by removing the trunnion attach shaft.

## 10. INSPECTION

1. Clean all parts with a suitable type cleaning solvent.
2. Inspect all bolt holes for elongation.  
**NOTE:** Replace the components with holes that are out of round by 0.005" or more. Replacement of the leaf spring forward attach bolt with a larger diameter is not approved. The leaf spring may not be "drilled out" for a larger bolt.
3. Inspect the main spring leaf for corrosion and cracks.  
**NOTE:** Check aircraft maintenance records to make sure that the spring leaf has not exceeded its five thousand (5,000) flight hour life limit. Replace the spring as needed.
4. Inspect the spindle housing assembly welds for cracks.
5. Inspect the spindle housing assembly for cracks and corrosion.
6. Inspect the lock pin and the upper and lower lock plates for wear, corrosion, cracks, and proper operation.
7. Inspect the centering springs for corrosion, wear at ends, and for correct operation.
8. Inspect the lock pin flexible cable and spring for corrosion and correct operation.
9. Inspect the Acetal (Delrin®) lower support block spacer for wear and cracks.  
**NOTE:** Replace the spacer if it has deteriorated.
10. Inspect the upper and lower leaf spring support blocks, and the attachment hardware for wear, corrosion, and cracks.  
**NOTE:** Ensure that the leaf spring support blocks grips the leaf spring tightly. Ensure the flexible sealant around the contact edges of the support blocks, lower support block spacer, and the leaf spring is intact to prevent collection of potential corrosive material in this area. Lubricate 2 ea. Trunion Zerk (grease) fittings with MIL-G-81322 (Aeroshell 22).  
**NOTE:** Repair of the tail landing gear is limited to replacement of component parts, bearings, bushings, blending out minor nicks and scratches, repainting chipped or peeled areas.

## 11. INSTALLATION

1. All bolt shanks and bolt holes are to be coated with Snap-on™ General Purpose Anti-seize lubricant or equivalent before installation.
2. Lubricate all bearings, bushings, and Zerk (grease) fittings with MIL-G-81322 (Aeroshell 22) grease.
3. Adjust trunnion as necessary to install strut tubes.

**NOTE:** Loosen fwd trunnion so that it can be rotated aft until aligned with struts. Loosely install bolt through struts, bushings, washers, and trunnion. Fwd trunnion should be retorqued only after struts have been torqued.

**NOTE:** Upon reassembly, lubricate bolt and leaf spring hole with Snap-on™ General Purpose Anti-seize or equivalent or MIL-G-81322 (Aeroshell 22) grease.

**NOTE:** Fill any gap between trunnion ears and spring with AN960C616/AN960C616L washers as necessary. Center spring in trunnion ears for best fit. Adjust bolt length plus one standard length as necessary, adjust washers as necessary to produce 1 min – 3 max thread protrusion through nut.

4. Locate and loosely install tail spring, struts, upper and lower support blocks and spacers, and hardware per Figures 11.1, 11.2, & 11.3.

**NOTE:** If titanium tail gear is installed, omit strap (P/N: 95426-23).

**NOTE:** If provided bolts will not go through holes in struts, ream holes using .376" ream bit.

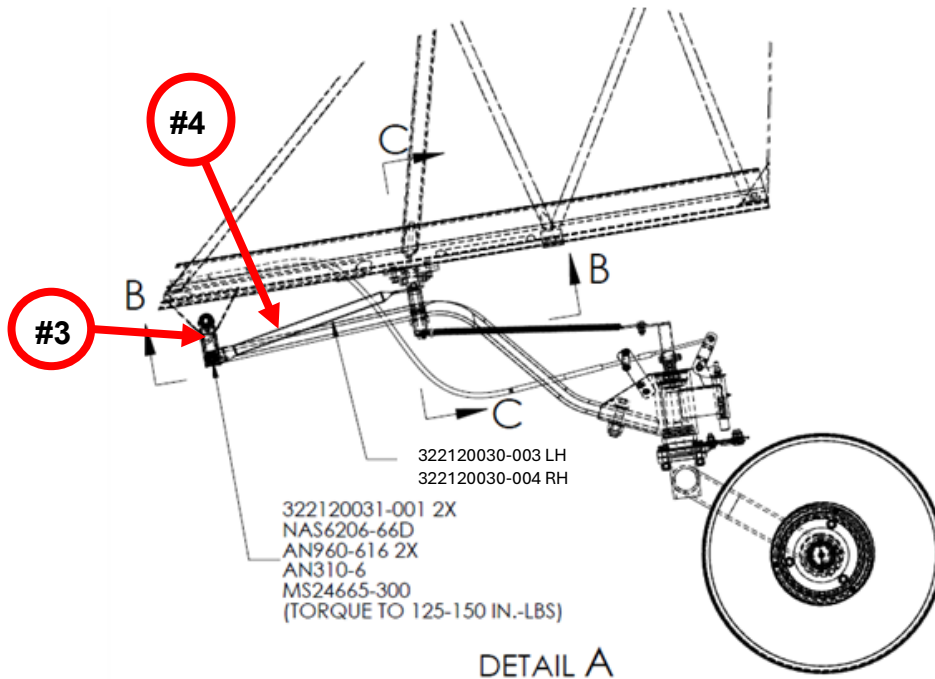
**NOTE:** At aft spacer block hardware location, install AN960C616/AN960C616L washers as necessary, any combination, 0 min – 4 max total, 2 washers maximum under bolt head or nut, to produce 1 min – 3 max thread protrusion through nut. Adjust washers as necessary to ensure no threads are in bearing.

5. Torque the fwd mount bolt (P/N: NAS6206-66D) to 125-150 inch-pounds then install cotter pin. (Reference Figure 11.3)

**NOTE:** DO NOT TORQUE NUT BEYOND MAXIMUM TORQUE RANGE. DISCARD ANY BOLTS THAT ARE OVERTORQUED.

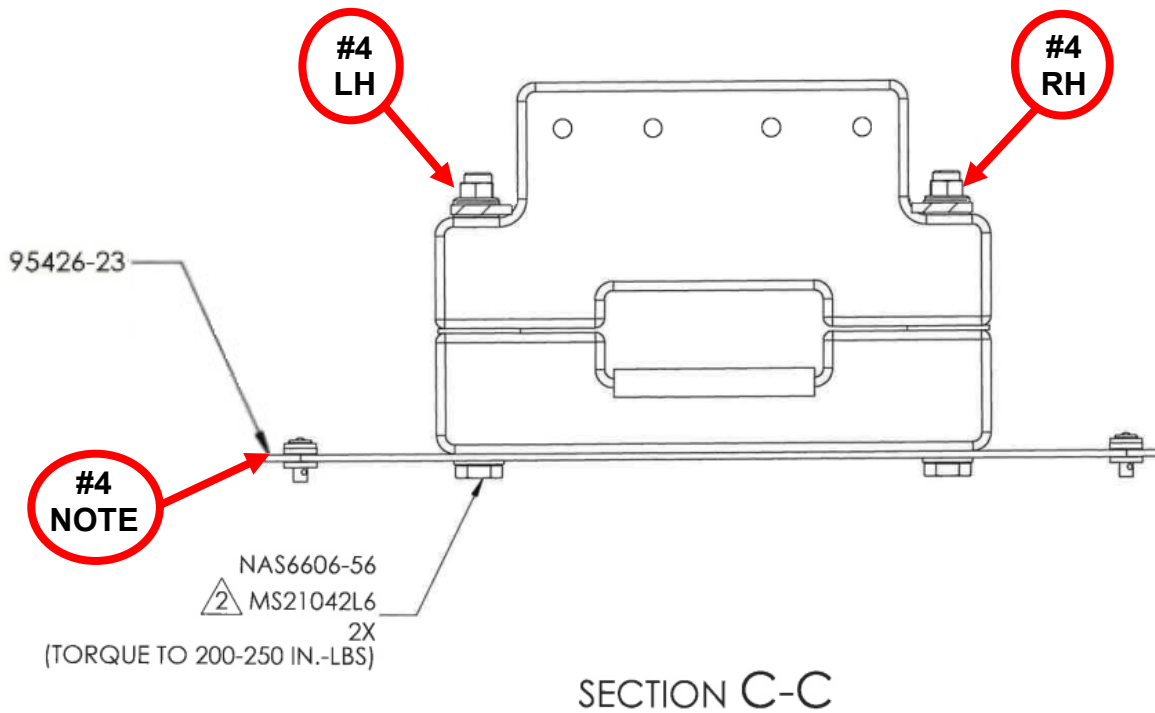
6. Torque the two aft mount bolts (P/N: NAS6606-56) in the tail spring support blocks to 200-250 inch-pounds. (Reference Figure 11.2)



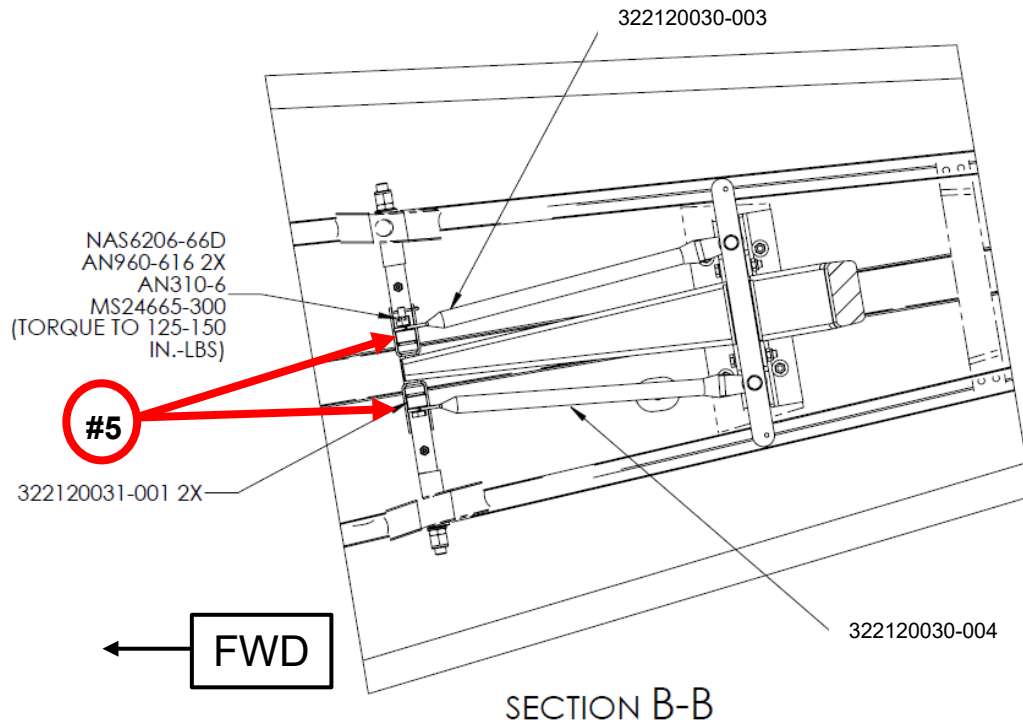


**Figure 11.1 Tail Wheel Installation Diagram**

\*\*\* Note that the position of the trunnion is not perpendicular as shown above but should be perpendicular or slightly forward when on the ground level. \*\*\*



**Figure 11.2 Tail Spring Support Blocks (Aft Mount) (View Looking Fwd)**



**Figure 11.3 Fwd Tail Mount Struts Installation  
(View Looking Up Under Belly Skin)**

7. Torque all remaining fasteners to specifications I.A.W. the torque chart found within the AMM, with the exception of the top spindle castellated nut and wheel/tire axle castellated nut, which should be torqued as follows:
  - a. For the spindle castellated nut: While manually rotating the spindle, torque the spindle castellated nut to 20 inch-pounds, continue rotating the spindle and back off to zero inch-pounds. While manually rotating the spindle, torque the nut to 10 inch-pounds. If not in the locking position, advance the nut to the next position, not to exceed 30°, and install the cotter pin. Bend the ends of the cotter pin around the spindle castellated nut.
 

**NOTE:** The spindle must rotate freely without perceptible axial play or binding.
  - b. For the tail wheel axle castellated nut: While manually rotating the wheel/tire, torque the axle castellated nut to 80 inch-pounds, continue rotating the wheel and back off to zero inch-pounds. While manually rotating the wheel/tire, torque to 30-40 inch-pounds. Rotate the axle castellated nut (clockwise or counterclockwise) to the nearest slot and cotter pin hole then insert the cotter pin. Bend the ends of the cotter pin around the axle nut.
 

**NOTE:** The wheel/tire must rotate freely without perceptible axial play or binding.

- c. After the components have been installed, seal the contact edges where the spring (which is to be replaced every 5,000 hours), upper support block, lower support block, and the spacer come together with a high-quality flexible silicone sealant or fuel tank sealant CS3204 B2 (AMS-S-8802 formerly MIL-S-8802).
- d. Carefully lower the aircraft to the ground and remove the jack.
- e. Recheck the tire inflation pressure (12.5 X 4.5 – 10 ply) 75 psi.
- f. (5.00-5 10 ply Type III is 88psi) Alternate.
- g. Reinstall the dust cover (hubcap).

## 12. FINAL INSPECTION

Perform a final inspection to ensure that the tail gear assembly and the forward tail mount struts have been properly installed and that the hardware has been properly torqued then apply torque stripe for verification of inspection.

### 13. COMPLIANCE

**Service Bulletin SB-AG-85 Rev. B Compliance Report**

Aircraft S/N:	Aircraft Owner:
Aircraft Registration #:	Address of Owner:
Airframe total time:	City & State:
Engine total time:	Physical location:
Complied with by:	Date of Compliance:
Signature:	Certificate #:

**PLEASE RETURN THIS REPORT ONLY AFTER INSPECTION AND MODIFICATION IS MADE**

This response card may be mailed, faxed to (229) 317-8225, or emailed to:  
[support@thrushaircraft.com](mailto:support@thrushaircraft.com)

Fold, Tape & Mail (Do Not Staple)

-----  
\_\_\_\_\_  
\_\_\_\_\_  
\_\_\_\_\_

Return Address:

**Thrush Aircraft, LLC  
Attn: Customer Support Team  
300 Old Pretoria Road  
Albany, GA 31721**